

Gigaset

C330 - C330 A

The base at a glance

Gigaset C330 /C330 A



- 1 **Display in idle status**
Indicates that the telephone is powered on.
- 2 **End/Back key**
- 3 **Control key** (→ page 16)
- 4 **INT key**
 - Making internal calls (→ page 18)
 - Registering handsets (→ page 29)
- 5 **Menu / OK key**
- 6 **One-touch memory keys** (→ page 44)
(C330 only)
Answering machine keys (→ page 2)
(C330 A only)
- 7 **Call list** (→ page 38)
- 8 **Redial key** (→ page 20)
- 9 **Mute key** (→ page 18)
Mute the microphone
- 10 **Recall key**
 - Consultation call (flash)
- Insert a dialling pause (press and hold)
- 11 **Speaker key** (LED)
Switch between earpiece and speaker mode
- 12 **Star key**
Ringtone on/off (press and hold);
with an open connection: switch between
pulse and tone dialling (press briefly);
- 13 **Priority key** (→ page 18)
Memory key for IP code (press and hold)
- 14 **Hash key**
Keypad lock on/off (press and hold in
idle status);

The base at a glance

Answering machine keys (C330 A only)

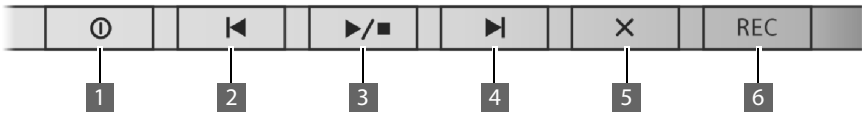

1 Answering machine key (→ page 44)

Switch answering machine (AM) on/off.

Lights up: AM is switched on.

Flashes: Unheard messages on the AM.

2 Skip back to the beginning of the message or skip back to the previous message (press twice).

3 Play/stop key

Play back new messages from answering machine or cancel playback (press **briefly**).

Press and hold to play announcements:

- AC (Answer and record)
- AO (Answer Only)

4 Skip to next message (press once) or next message but one (press twice).

5 Delete key

6 Record once key (Memo)

Base display symbols

The following symbols are displayed dependent on the settings and the operating status of your telephone:

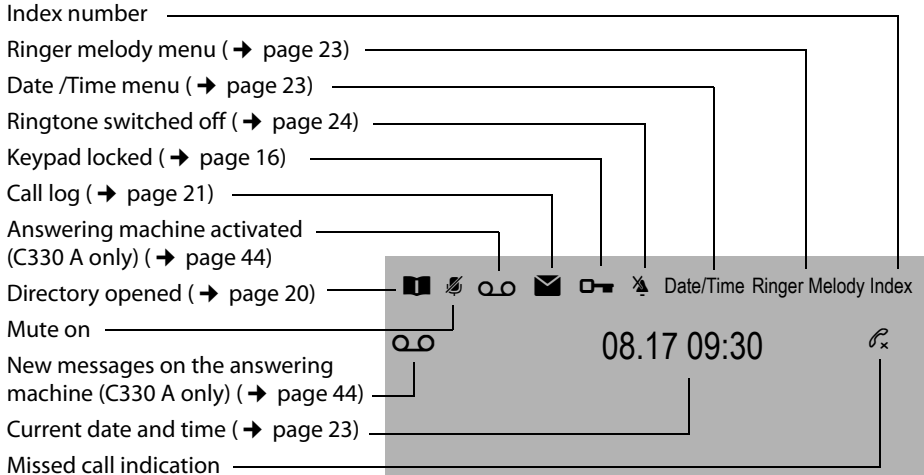

The handset at a glance

The handset at a glance

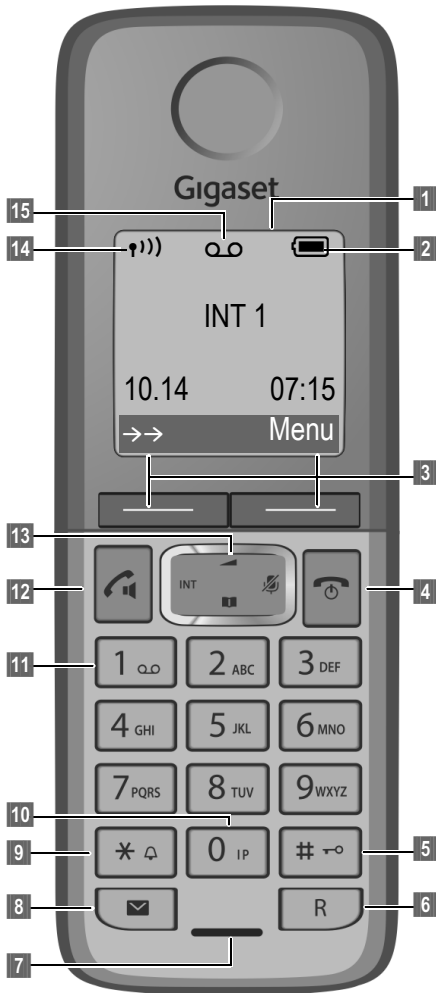

- 1 Display in idle status
- 2 Battery charge status
(→ page 5)
- 3 Display keys (→ page 25)



- 4 **End call key, On/Off key**
End call, cancel function, go back one menu level (press briefly), back to idle status (press and hold), activate/deactivate handset (press and hold in idle status)
- 5 **Hash key**
Keypad lock on/off (press and hold in idle status);
toggles between upper/lower case and digits
- 6 **Recall key**
– Consultation call (flash)
– Insert a dialling pause (press and hold)
- 7 **Microphone**
- 8 **Message key** (→ page 38)
Access to calls and message lists;
Flashes: new message or new call
- 9 **Star key**
Ringtone on/off (press and hold);
with an open connection: switch between dial pulsing/tone dialling (press briefly);
- 10 **Priority key** (→ page 33)
Memory key for IP code (press and hold)
- 11 **Key 1** (→ page 46)
Dial answering machine (C330 A only) (press and hold)
- 12 **Talk key**
Flashes: incoming call;
Accept a call (press briefly);
- 13 **Control key** (→ page 25)
 - ☐ initiate an internal call;
 - ☐ mute the microphone during a call;
 - ☐ open audio settings;
 - ☐ open the directory;
- 14 **Signal strength symbol** of the connection to the base
- 15 **Answering machine symbol** (C330 A only) (→ page 46)
Flashes: Answering machine switched on;
Flashes: Answering machine is recording a message or is being operated by another internal party.

You can register up to four handsets to the Gigaset C330/330 A (→ page 29).

The handset at a glance

Handset display symbols

The following symbols are displayed dependent on the settings and the operating status of your telephone:

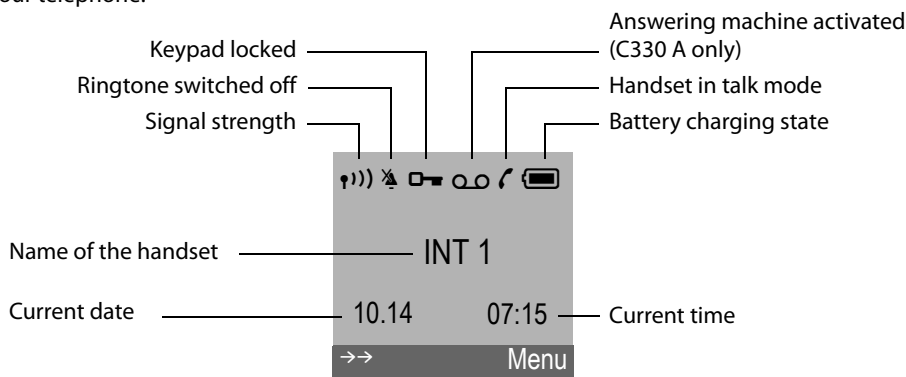

Message indication



New messages
 OO on the answering machine (C330 A only)
 ⓧ in the list of missed calls

Alarm indication



Alarm switched on and wake-up time

Signalling

External call



Internal call







Alarm clock

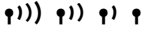

The handset at a glance

Display in idle status

- ◆ Reception signal between the base and handset:
good to poor: 

If the handset goes out of range a warning tone will be heard.
- ◆ Battery charge status:
 -  (empty to full)
 -  low warning tone: batteries almost empty
 -  during charging, the symbol changes periodically
- ◆ INT 1
Internal name of the handset (default).
- ◆ If the answering machine is activated, the  symbol will be displayed in the header (Gigaset C330 A only).



For more information about your telephone, visit www.gigaset.com/cn.

Have fun using your new phone!

Contents

Contents

The base at a glance	1
Gigaset C330 /C330 A	1
Base display symbols	2
The handset at a glance	3
Handset display symbols	4
Safety precautions	9
First steps	10
Checking the pack contents	10
Setting up the base and handset charging cradle	11
Setting up the handset for use	13
Setting the date and time	14
What would you like to do next?	15
The Gigaset C330/330 A base	16
Using the base	16
Control key	16
Keys on the keypad	16
Activating/deactivating the keypad lock	16
Reverting to idle status	16
Making calls	17
Making an external call	17
Quick dialling	17
Ending a call	17
Accepting a call	17
Calling Line Identification (CLI)	17
Speaker mode	18
Adjusting the earpiece/speaker volume during a call	18
Switching to mute	18
Making internal calls	18
Transferring a call	18
Internal consultation/conference calls	19
Accepting/rejecting call waiting	19
Using the directory and lists	20
Directory	20
Redial list	20
Call lists	21
One-touch memories (C330 only)	22

Base settings	23
Setting the date and time	23
Setting the earpiece and speaker volume	23
Setting the ringer	23
System settings	24
The Gigaset C330H handset	25
Using the handset	25
Control key	25
Display keys	25
Keys on the keypad	26
Correcting incorrect entries	26
Activating/deactivating the keypad lock	26
Activating/deactivating the handset	26
Menu guidance	26
Handset menu overview	27
Registering handsets	29
De-registering handsets	29
Locating handsets (paging)	30
Making calls	31
Making an external call	31
Quick dialling	31
Ending a call	31
Accepting a call	31
Calling Line Identification (CLI)	32
Speaker mode	32
Adjusting the earpiece/speaker volume during a call	32
Switching to mute	32
Battery status control during a call	33
IP dialling	33
Making internal calls	34
Transferring a call	34
Internal consultation/conference calls	34
Accepting/rejecting call waiting	35
Barging in to an external call	35
Using the directory and lists	36
Directory	36
Redial list	37
Call lists	38

Contents

Handset settings	39
Changing the display language	39
Setting the date and time	39
Setting the alarm clock	39
Audio settings	40
Setting the display	41
Activating/deactivating auto answer	41
System settings	41
Connecting the telephone to the PABX	43
Changing the dialling mode	43
Setting recall	43
Setting an automatic prefix	43
Temporarily switching to tone dialling (DTMF)	43
Operating the answering machine (Gigaset C330 A only)	44
Operation via the base	44
Activating/deactivating the answering machine	44
Setting the answering machine mode	44
Playing back messages	44
Picking up a call from the answering machine	45
Activating/deactivating call screening	45
Recording an announcement	45
Operation via the handset	46
Activating/deactivating the answering machine	46
Playing back messages	46
Picking up a call from the answering machine	47
Activating/deactivating call screening	47
Announcements	47
Setting the answering machine mode	48
Setting the ring delay	48
Remote operation	48
Calling the answering machine	48
Operating the answering machine remotely	49
Replaying messages remotely	49
Activating/deactivating the answering machine remotely	49
Customer Service & Assistance	50
Questions and answers	50
Appendix	51
Care	51
Contact with liquid	51
Specifications	51
Writing and editing text	52
Index	54

Safety precautions

Warning

Read the safety precautions and the user guide before use.

Explain their content and the potential hazards associated with using the telephone to your children.



Only use the mains adapters supplied, as indicated on the underside of the base.



Only use the **recommended, rechargeable batteries** (→ page 51) as this could otherwise result in significant health risks and personal injury.



The operation of medical appliances may be affected. Be aware of the technical conditions in your particular environment, e.g. doctor's surgery.



Do not hold the rear of the handset to your ear when it is ringing or when speaker mode is activated. Otherwise you risk serious and permanent damage to your hearing.

Your Gigaset is compatible with the majority of digital hearing aids on the market. However, perfect function with all hearing aids cannot be guaranteed.

The handset may cause an unpleasant humming or whistling noise in hearing aids or cause them to overload. If you require assistance, please contact the hearing aid supplier.



Do not install the base or charging cradle in bathrooms or shower rooms. The base is not splashproof (→ page 51).



Do not use your phone in environments with a potential explosion hazard (e.g. paint shops).



If you give your Gigaset to someone else, make sure you also give them the user guide.



Please remove faulty bases from use or have them repaired by our Service department, as they could interfere with other wireless services.

First steps

First steps

Checking the pack contents



1. one Gigaset C330 or C330 A base
2. one Gigaset C330H handset
3. one charger for Gigaset C330H
4. two batteries
5. one battery cover

6. one receiver
7. one receiver cable
8. one phone cable
9. one mains adapter
10. this user guide C330/C330A
(not pictured)

Setting up the base and handset charging cradle

The base and charging cradle are designed for use in enclosed dry rooms with a temperature range of +5°C to +45°C.

- ▶ Install the base on a level, non-slip surface in a central location in your house or flat.

Please note

Make sure you observe the range of the base for the handset connection. This is up to 300 m in unobstructed outdoor areas and up to 50 m inside buildings.

The phone's feet do not usually leave any marks on surfaces. However, due to the multitude of different varnishes and polishes used on today's furnishings, the occurrence of marks on the surfaces cannot be completely ruled out.

- ▶ The display is protected by a plastic film. **Please remove the protective film!**

Please note:

- ◆ Never expose the telephone to the influence of heat sources, direct sunlight or other electrical devices.
- ◆ Protect your Gigaset from moisture, dust, corrosive liquids and vapours.

Connecting the base

- ▶ Connect the receiver to the telephone using the coiled cable supplied **1**.
- ▶ Connect the telephone jack **2**.
- ▶ Then connect the mains adapter **3**.
- ▶ Insert the cable of the mains adapter into the cable ducts **4**.

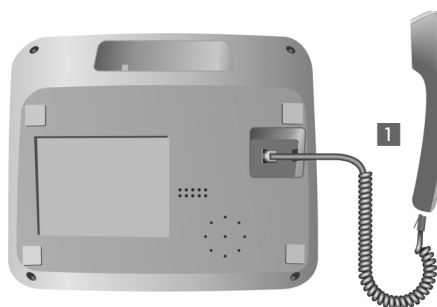

Please note:

- ◆ The mains adapter must **always be connected**, as the phone will not operate without a mains connection.
- ▶ Only use the mains adapter and phone cord **supplied**. Pin connections on telephone cables can vary (pin connections → page 52).

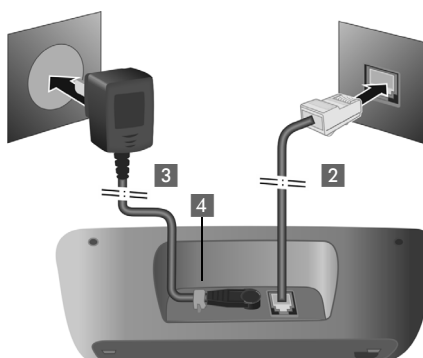

First steps

Connecting the handset charging cradle

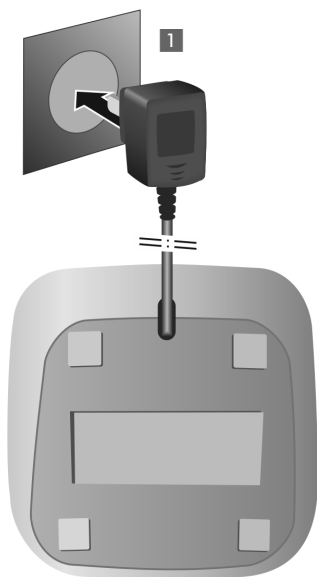

► Plug the mains adapter into the plug socket **1**.

Setting up the handset for use

The display is protected by a plastic film. **Please remove the protective film!**

Inserting the batteries and closing the battery cover

Warning

Only use the rechargeable batteries (→ page 51) recommended by Gigaset Communications GmbH, i.e. never use conventional (non-rechargeable) batteries, as this could result in significant health risks and personal injury. For example, the outer casing of the batteries could be damaged or the batteries could explode. The phone could also malfunction or be damaged as a result of using batteries that are not of the recommended type.

- ▶ Insert the batteries the right way round. The polarity is indicated in/on the battery compartment.

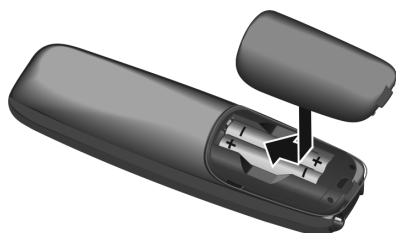
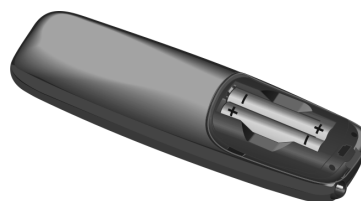

- ▶ First insert the battery cover from above.
- ▶ Then press the cover until it clicks into place.

To reopen the battery cover to replace the battery:

- ▶ Insert your fingernail into the notch on the top of the cover and push downwards.

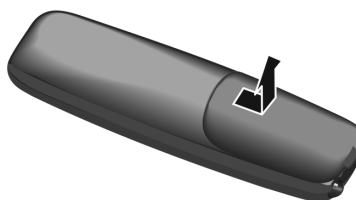

First steps

Placing the handset in the charging cradle

- ▶ Place the handset in the charging cradle with its **display facing forward**.

The supplied handset is registered with the base at the factory. You do not need to register it. If you wish to use your handset with a different base or use further handsets with your base, you will have to register them manually, → page 29.

To charge the batteries, leave the handset in the charging cradle.

Please note

Only place the handset in the charging cradle that is intended for it.

Initial charging and discharging of the batteries

The correct charge level can only be displayed if the batteries are first fully charged **and** discharged.



- ▶ Place the handset in the charging cradle for **12 hours**.



- ▶ Then remove the handset from the charging cradle and do not replace it until the batteries are fully discharged.

Please note

- ◆ After the first battery charge **and** discharge you may replace your handset in the charging cradle after every call.
- ◆ Always repeat the charging and discharging procedure if you remove the batteries from the handset and re-insert them.
- ◆ The batteries may warm up during charging. This is not dangerous.
- ◆ After a while, the charge capacity of the batteries will decrease for technical reasons.

Setting the date and time

Set the date and time so that the correct date and time can be assigned to incoming calls, and so that the alarm can be used. You can set the date and time on the base (→ page 23) or on any registered handset (→ page 39).

Your telephone is now ready to use!









What would you like to do next?

Now you have successfully started your Gigaset, you will probably want to adapt it to your personal requirements. Use the following guide to quickly locate the most important subjects.

If you are unfamiliar with menu-driven devices such as other Gigaset telephones you should first read the sections "Using the base" on page 16 or "Using the handset" on page 25.

Information on ...

... is located here.

Setting the ringtone and volume	for the base	 page 23
	for the handset	 page 40
Setting the earpiece volume	for the base	 page 23
	for the handset	 page 40
Recording a personal announcement for the answering machine (C330 A only)	on the base	 page 45
	on the handset	 page 47
Operating the telephone on a PABX		 page 43
Registering new Gigaset handsets to the base		 page 29



If you have any questions about using your phone, please read the tips on troubleshooting (→ page 50) or contact our Customer Care team (→ page 50).

Using the base

The Gigaset C330/330 A base

Using the base



Control key

Below, the side of the control key you need to press in the respective operating situation is marked by an arrow (top, bottom, right, left), e.g.  for "press right on the control key" or  for "press at the top of the control key".





The control key has a number of different functions:

When the base is in idle status

-  Open the directory.
-  Increase the ringer volume.
-  Decrease the ringer volume.



In the menu

-  or  Navigate to the required function.

In lists

-  /  Scroll up/down line by line.

During a call

-  Open the directory.
-  /  Adjust the loudspeaker volume for earpiece and speaker mode.

Keys on the keypad

 /  /  etc.

Press the matching key on the keypad.



Enter digits or letters.

Activating/deactivating the keypad lock

The keypad lock prevents any inadvertent use of the phone.



Press and **hold** the hash key in idle status to activate or deactivate the keypad lock. You will hear the confirmation tone.

If the keypad lock is activated, the  symbol is displayed and a warning tone will be emitted when you press a key.

The keypad lock deactivates automatically when you receive a call. It is reactivated when the call is ended.

Please note

When the keypad lock is active, you can call emergency numbers only by using the receiver at the base.

Reverting to idle status

You can revert to idle status from anywhere in the menu as follows:

- ▶ Press the back key .

Or:

- ▶ Do not press any key: after 2 minutes the display will **automatically** revert to idle status.

Or:

- ▶ Briefly lift the corded handset.

Making calls

You make a call using the phone's receiver or the speaker.

Making an external call

External calls are calls using the public telephone network.



Enter the number and lift the receiver.

Or:





Lift the receiver and then enter the number.

The number is limited to 24 digits.

Instead of using the receiver:



Press the speaker key to make a call via the speaker. The LED lights up permanently.

You can also switch at any time during the call. Throughout the whole of this section, the  (or ) symbol can always represent .

If the line is in use by a handset **Line In Use** is displayed.

Please note

Dialling with the directory (→ page 20), call list (→ page 21) redial list (→ page 20) or memory key (→ page 22) saves you from repeatedly keying in phone numbers.

Quick dialling

You can dial a number directly via a digit key

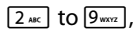

provided a number stored in the directory has been assigned to the digit key using the handset, → page 37.

When the base is in idle status:

- ▶ Press and **hold** the digit key.
The number is dialled immediately.

Ending a call





Put down the receiver, or press the speaker key  if the call was made handsfree.

Accepting a call

The base indicates an incoming call in three ways: by ringing, by a display on the screen and by the flashing talk LED.

You can accept the call by:

- ▶ Lifting the receiver .
- ▶ Pressing the speaker key  to make the call handsfree.

To deactivate the ringtone, press the  key. You can accept the call as long as it is displayed on the screen.

Calling Line Identification (CLI)

Calling Line Identification is a telephony service that transmits caller identification information (name or number). When you receive a call, the caller's number is displayed on the screen according to the following rules:

Number is transmitted

If the number is transmitted it is displayed. If the number exceeds 24 digits, only the first 24 digits are displayed.

Number is not transmitted

The base rings but nothing is displayed.

Please note

The name of the caller is only displayed on the handset (→ page 32).

Making internal calls

Speaker mode

Instead of putting the receiver to your ear you can make a call using the speaker. This allows other people to participate in the call.

Activating/deactivating speaker mode

Activating while dialling



Enter the number and press the speaker key.

When the speaker mode is activated, the  key lights up.

- ▶ You should inform your caller before you use the speaker function so that they know someone else is listening.

Switching between earpiece and speaker mode



Press the speaker key.

During a call and when listening to the answering machine (Gigaset C330 A only), activate or deactivate speaker mode.

If you wish to place the receiver in the base during a call:

- ▶ Press and hold the speaker key  while placing the receiver in the base.

For instructions on how to adjust the loud-speaker volume, → page 23.

Adjusting the earpiece/speaker volume during a call

To adjust the earpiece or speaker volume during a call:



Use the control key to adjust the volume in five levels.

Switching to mute

You can deactivate the microphone in the receiver of the base during an external call.



Press the key to mute the microphone. The display shows the mute symbol . Press the key again to reactivate the microphone.

Making internal calls

Internal calls between the base and the handset or to other handsets registered on the same base are free.

An internal call is indicated by the paging tone, which is different from the incoming tone.

Calling all handsets



Initiate the internal call.



Lift the receiver or press the speaker key .

All handsets are called. The connection will be established with the first answering handset. All other handsets cannot participate.

Ending a call



Replace the receiver or press the speaker key .

Transferring a call

You can transfer an external call to any handset.

During an external call:



Press the key to page all registered handsets. The external participant is put on hold.

Either:



Press the key or replace the receiver to transfer the call to the first answering handset.

If no handset answers within 30 sec. the call is transferred back to the base.

Or:

Wait until an internal participant answers. If necessary, announce the external call.



Replace the receiver.

The external call is transferred to the handset.

If no internal participant answers or the line is busy, press the  key again to return to the external call.

Internal consultation/ conference calls

When you are conducting an **external** call, you can call an **internal** participant at the same time for consultation or hold a conference call between all 3 participants.

You are conducting an **external** call:



Press the key to page all registered handsets.

The external participant is put on hold.

The connection will be established with the first answering handset for consultation.

Either:



Press the key.

You are reconnected with the external participant.

Or:



Press and hold the key.

Ending a conference call



Replace the receiver.

If an **internal** participant ends the call, the other remains connected to the external participant.

Please note

Conferences are only possible between one external and two internal participants.

Accepting/rejecting call waiting

If you receive an **external** call during an **internal** call, you will hear the call waiting tone (short tone). The caller's number will appear in the display if Calling Line Identification is enabled.

Accepting the external call

Either:



Press the speaker key if you are conducting the internal call via the receiver.



Lift the receiver if you are conducting the internal call via speaker.

The internal call is **ended** and you are connected to the external caller.

Or:



Press the key to answer the call and put the internal participant on hold.

Press  again to toggle between the external and the internal participant.

Rejecting the external call

Ignore the call waiting. You remain connected with the internal participant. The ringtone can still be heard on other registered handsets.

The caller is forwarded to the answering machine if activated (Gigaset C330 A only).

Using the directory and lists

Using the directory and lists

The following options are available to store information on calls, contacts and numbers:

- ◆ Directory
- ◆ Redial list, → page 20
- ◆ Call lists, → page 21
- ◆ One-touch memories, → page 22

Please note

The directory, call lists and shortcuts are saved in the base and shared with all registered handsets. Editing entries or copying numbers from the call list to the directory is only possible via handset. Changes apply to all handsets.

Directory

Storing and editing entries in the directory is only possible via handset → page 36.

The directory can hold up to 150 entries. A directory entry contains one number and an associated name. On the base only the number is displayed.

Opening the directory

To open the directory in idle status:

-  Press the directory key (control key down).

Order of directory entries



Directory entries are generally sorted alphabetically. Spaces and digits take first priority.

The sort order is as follows:





1. Digits (0–9)
2. Space
3. Other characters
4. Letters (alphabetical)

To get round the alphabetical order of the entries, insert a space or a digit in front of the first letter of the name. These entries will then move to the beginning of the directory.

Selecting/viewing a directory entry

-  Open the directory.
-  Scroll through the entries until the required number is displayed.

Dialling with the directory



-  →  Open the directory, select the desired entry.
-  Lift the receiver or press the speaker key . The number is dialled.

Redial list



The redial list contains the 20 numbers last dialled on the base (max. 32 digits).

The redial list is arranged in reverse chronological order, i.e. the last dialled number is the first number in the list.

Manual redial

-  Lift the receiver or press the speaker key .
-  Press the redial key. The number is dialled.

Or:

-  Press the redial key.
-  Lift the receiver or press the speaker key . The first number is dialled.

To dial the second, third, ... stored number, press  twice, three times, etc..

Managing entries in the redial list

 Press the redial key **briefly**.

 Select an entry.

Deleting an entry

 Press the delete key.

 Press the **OK** key to confirm. A confirmation tone is emitted. The redial list is displayed.

To cancel deleting, press the  key.

Deleting the redial list

 Press and hold the delete key until “---” is displayed.

 Press the **OK** key to confirm. A confirmation tone is emitted. The redial list is displayed.

To cancel deleting, press the  key.

It is not possible to copy entries from the redial list into the directory.

Call lists

Requirement: Calling Line Identification, → page 17.

The telephone stores a maximum of 30 numbers in the call list. The following types of call are available:

- ◆ Accepted calls
- ◆ Missed calls

In idle mode the  symbol indicates that there are new missed calls in the call list.

Opening the call list

In idle status:

 Press the call list key.

List entry

The calls are displayed in chronological order.



An entry shows

- Time and date of the call
- Number of caller

Dialling from the call list



Lift the receiver or press the speaker key  to return the call selected.

Managing entries in the call list



Press the call list key.



Select an entry.

Deleting an entry



Press the delete key.



Press the **OK** key to confirm. A confirmation tone is emitted. The call list is displayed.

To cancel deleting, press the  key.

Deleting the call list



Press and hold the delete key until “---” is displayed.



Press the **OK** key to confirm. A confirmation tone is emitted. The call list is displayed.

To cancel deleting, press the  key.

When you quit the call list, all entries are set to the status "old"; i.e. the  symbol is no longer displayed.





Using the directory and lists

One-touch memories (C330 only)

Your Gigaset C330 provides six one-touch memories to store frequently dialled numbers. You can then call a number directly by pressing the corresponding memory key.

Storing a number

In idle mode

 /  /  /  /  / 

Press and hold one of the memory keys.



Enter the telephone number (up to 24 digits).



If necessary, press and hold to enter a pause.







Press the **OK** key to save the number.

Dialling a stored number



Lift the receiver or press the speaker key .

 /  /  /  /  / 

Press the memory key on which the desired number is stored. The number is dialled.

Or:

 /  /  /  /  / 

Press a memory key to display the stored number.



Lift the receiver or press the speaker key . The number is dialled.

Base settings

Your telephone is preconfigured, but you can change the settings to suit your individual requirements.

Setting the date and time



Press the key to open the display menu. The **Date/Time** symbol flashes.



Press the key again to start the date and time settings.



Press the right/left control key to change the input position and correct an entry.



Enter the month and day as a 4-digit number via the keypad, e.g. **0** **9** **2** **6** for 26/09/. The date format depends on your country settings.



Enter the hours and minutes in 4-digit format via the keypad, e.g. **0** **7** **1** **5** for 07:15 am.



Press the up/down key to switch between the 12- and 24-hour time formats.



Press the key to save your settings.

You will hear a confirmation tone and the display will automatically return to idle mode.

Please note

The displayed format for date and time depends on your country.

Setting the earpiece and speaker volume

You can set the loudspeaker volume for handsfree talking and the earpiece volume to five different levels during a call.

Setting the earpiece volume



Set the earpiece volume; the level (L1... L5) is displayed.

Setting the speaker volume



Set the speaker volume; the level (L1... L5) is displayed.

Setting the ringer

You can set the ringer volume to six different levels and select a ringtone.

Setting the ringer volume

In idle status:



Press the left or right control key.

L0....L5

The volume level currently set is shown. The ringer melody currently set is replayed.







When the ringer volume is set to L0 (off), L0 is displayed and the  symbol appears in the display.

The ringer volume can also be adjusted during an incoming call, but this setting is not permanent.

Base settings

Setting the ringtone



You can select a ringtone from a list of 5 pre-loaded ringtones.

-  Press the key to open the display menu. The **Date/Time** symbol flashes.
-  Press the **right** or **left** control key until the **Ringer Melody** symbol flashes.
-  Press the key to enter the **Ringer Melody** setting mode. The current ring melody plays from the speaker and the number is displayed.
-  Select the desired melody (or enter the number) and press **OK**.
-  Press the **right** or **left** control key to adjust the volume.
-  Press the key to save your settings.

Activating/deactivating the ringtone

You can deactivate the ringtone on your handset before you answer a call or when the handset is in idle status; the ringtone can be deactivated permanently or just for the current call. The ringtone cannot be re-activated while an external call is in progress.

Deactivating the ringtone permanently

-  Press and **hold** the star key. The  symbol appears in the display.

Reactivating the ringtone

-  Press and **hold** the star key.

System settings

System settings apply to the entire phone system. They can only be set on a registered handset (→ page 41).

The Gigaset C330H handset

The Gigaset C330/330 A comes with one Gigaset C330H handset. The handset is already registered to the base.

You can register up to four handsets to your base, → page 27.

Using the handset

Control key

Below, the side of the control key that you must press in the respective operating situation is marked by an arrow



(top, bottom, right, left), e.g. for "press right on the control key" or for "press at the top of the control key".

The control key has a number of different functions:

When the handset is in idle status

- Open the directory.
- Open the main menu.
- Open the list of internal phones (base and handsets).
- Open the **Audio Setting** sub-menu.

In the main menu

- , , or
- Navigate to the required function.

In submenus and lists

- / Scroll up/down line by line.

In input fields

Use the control key to move the cursor up , down , right or left .

During a call

- Open the directory.
- Adjust the loudspeaker volume for earpiece and speaker mode.
- Activate mute function.

Display keys

The functions of the display keys change depending on the particular operating situation. Example:

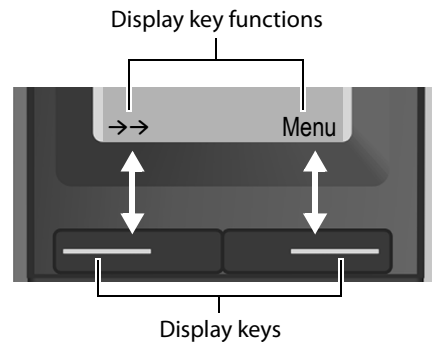



Some important display keys:

- Menu** Open the menu.
- Options** Open a submenu for further functions.
- OK** Confirm selection.
- < C** Delete key: delete one character/word at a time from right to left.
- Back** Go back one menu level or cancel operation.
- Save** Store entry.

In the following description the instruction "press the display key **XXX**" means: "press the display key below the display key function labelled **XXX**".

Using the handset

Keys on the keypad

 /  /  etc.

Press the matching key on the keypad.



Enter digits or letters.

Correcting incorrect entries

You can correct incorrect characters in the input fields by navigating to the incorrect entry using the control key. You can then:

- ◆ Delete the **character** by briefly pressing **<C>** or press and **hold** to delete the **word** to the left of the cursor.
- ◆ Insert characters next to the cursor.
- ◆ Overwrite the highlighted (flashing) character, e.g. when entering time and date.

Activating/deactivating the keypad lock

The keypad lock prevents any inadvertent use of the phone.



Press and **hold** the hash key in idle status to activate or deactivate the keypad lock. You will hear the confirmation tone.

If the keypad lock is activated, the  symbol is displayed and a warning tone will be emitted when you press a key.

The keypad lock deactivates automatically when you receive a call. It is reactivated when the call is ended.

Please note

When the keypad lock is active, you cannot call emergency numbers using the handset. In this case use the corded receiver at the base for emergency calls.

Activating/deactivating the handset



With the phone in idle status, press and **hold** the end call key (confirmation tone) to switch off the handset.

Press and **hold** the end call key again to switch the handset on.

Menu guidance

Your telephone's functions are accessible using a menu that has a number of levels. The full menu tree is shown in the next section, → page 27.

Please note

In these instructions, opening the main menu is represented by pressing right on the display key. However, if you prefer, you can use the control key as described above (→ page 25).

Main menu (first menu level)

- ▶ When the handset is in idle status press the **Menu** display key to open the main menu.

The main menu functions are shown in the display. The selected function is marked in black.

Date/Time	
Audio Setting	
HS Setting	
Back	OK

To access a function, i.e. to open the corresponding submenu (next menu level):

- ▶ Use the control key  to select the required function and press the display key **OK**.



To return to the previous menu level or to cancel the operation.

- ▶ **Briefly** press the display key **Back**.

Submenus

The functions in the submenus are displayed as lists (example on the right).

To access a function:

- ▶ Scroll to the function with the control key  and press **OK**.
- ▶ Briefly press the display key **Back** or the end call key  to return to the previous menu level/cancel the operation.

Language
Auto Answer
Register HS
Back OK

Reverting to idle status

You can revert to idle status from anywhere in the menu as follows:

- ▶ Press and **hold** the end call key .

Or:

- ▶ Do not press any key: after 2 minutes the display will **automatically** revert to idle status.

Settings that have not been saved by selecting the display key **OK** or **Save** will be lost.

An example of the display in idle status is shown on page 5.

Illustration of menu operation in the user guide



Menu operations are shown in the user guide in abbreviated form.

Example:

The illustration:

Menu → **Audio Setting** → **Ringer Setting**
→ **Ringer Melody**

means:

- ▶ Press the **Menu** display key to open the menu.
- ▶ Select the **Audio Setting**, press **OK**.
- ▶ Use the control key  to select **Ringer Setting**, press **OK**.
- ▶ Use the control key  to select **Ringer Melody**, press **OK**.

Handset menu overview

To open the main menu press the **Menu** display key.

Date/Time	Date/Time	→ page 39
	Alarm Clock	Activation → page 39
		Alarm Time → page 39
Audio Setting	Call Volume	→ page 40
	Ringer Setting	Ringer Volume → page 40
		Ringer Melody → page 40
	Advisory Tones	→ page 41

Using the handset

HS Setting	Language		→ page 39	
	Auto Answer		→ page 41	
	Register HS		→ page 29	
	De-register HS		→ page 29	
	Screen Saver		→ page 41	
	Contrast		→ page 41	
System Setting	Time Control		→ page 41	
	System PIN		→ page 42	
	Add. Features	Dialing Mode		→ page 43
		Flash Time		→ page 43
		Conference		→ page 35
	Auto Prefix	Activation		→ page 43
		Prefix No.		→ page 43
	Call List Type		→ page 38	
	System Reset		→ page 42	
	Voice Mail	Play Messages		→ page 46
Answerphone			→ page 46	
Call Screening			→ page 47	
Announcement		Rec. Announcement		→ page 47
		Play Announcement		→ page 48
		Del. Announcement		→ page 48
Answer mode			→ page 48	
Ring Delay			→ page 48	

Registering handsets

Manual registration of the Gigaset C330H on Gigaset C330/330 A

If you want to register additional handsets, you must activate manual registration of the handset (1) on both the handset (2) and the base.

When the registration process has completed successfully, the handset returns to idle status. The handset's internal number is shown in the display e.g. INT 1. If not, repeat the procedure.

On the handset

If the handset is not registered to a base the display shows:

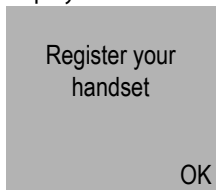

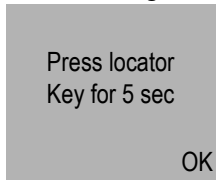

OK Press the display key to start the registration.



OK Press the display key to confirm.

On the base

Within 60 seconds, press and **hold** the registration/paging key  (→ page 1) for approx. 5 seconds.

The speaker key (LED)  flashes and you will hear a beep.

On the handset



Enter the current system PIN and press **OK**.

A message indicates that the system is searching for a base that is ready for registration.

Please note

If four handsets are already registered, no additional handset can be registered to the base. If the 5th handset intends to register to the base, an error tone is output and the display shows **Memory Full**.

De-registering handsets

You can de-register any other registered handset from any registered Gigaset C330H handset.

Menu → **HS Setting** → **De-register HS**



Select the internal subscriber you wish to deregister and press **OK**.



Enter the current system PIN and press **OK**.

OK

Press the display key to confirm the action.

Using the handset

Locating handsets (paging)

From the base

You can locate your handsets using the base.

 Press the key on the base.

All called handsets will ring simultaneously (paging), even if the ringtones are deactivated.

Ending paging

 Press the key again on the base.

From the handset

You can locate another handset using your handset.

 **Briefly** press the INT key (control key on the left).

 Use the control key to select the handset to be called or select **Call All** to locate the base and all registered handsets.

 Press the display key to start paging.

All called handsets and the base will ring simultaneously (paging), even if the ringtones are deactivated.

Ending paging

 Press the display key to stop paging.

Please note

In the case of an incoming external call the paging is stopped.

Making calls

If the back light is deactivated (→ page 41) it is switched on by pressing any key. In this case the pressed key has no other function.

Making an external call

External calls are calls using the public telephone network.



Enter the number and press the talk key.

Or:



Press the talk key and then enter the number.

The number is limited to 24 digits.

You can cancel the dialling operation with the end call key.

An ongoing call is indicated by:



You are shown the duration of the call while the call is in progress.

If the line is in use by the base or another handset, **Line In Use** is displayed.

Please note

Dialling with the directory (→ page 36), call list (→ page 38) and redial list (→ page 37) saves you repeatedly key-
ing in phone numbers

Quick dialling

You can assign a **number from the directory** to each of the **digit keys** [2_{ANC}] to [9_{MAX}], → page 39.

When the handset is in idle status:

- ▶ Press and **hold** the digit key.
The number is dialled immediately.

Or:

- ▶ **Briefly** press the digit key:
Press the display key with number/name (abbreviated if necessary) to dial the number.

Please note

If no quick dial number has been stored on the digit key, the directory opens, allowing you to assign a number, → page 36.

Ending a call



Press the end call key.

The end of the call is indicated by:



Accepting a call

The handset indicates an incoming call in three ways: by ringing, by a display on the screen and by the flashing talk key.

You can accept the call by:

- ▶ Pressing the talk key.

Or:

- ▶ Pressing the **Accept** display key.

If the handset is in the charging cradle and the **Auto Answer** function is activated (→ page 41), the handset automatically answers the call when you remove it from the charging cradle.

To deactivate the ringtone, press the **Silence** display key. You can accept the call as long as it is displayed on the screen.

Making calls

Calling Line Identification (CLI)

Calling Line Identification is a telephony service that transmits caller identification information (number and name). When you receive a call, the caller's number and/or name is displayed on the screen according to the following rules:

Number/name is transmitted and stored in the directory

The caller's number and the name according to the directory entry are displayed.

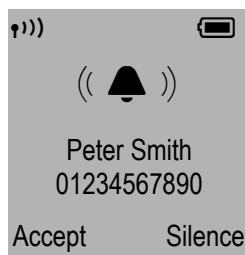

Number/name is transmitted but not stored in the directory

If the number is transmitted it is displayed. If the name is transmitted, it replaces the number.

If the name exceeds 16 characters, only the first 16 characters are displayed. If the number exceeds 24 digits, only the first 24 digits are displayed.

Number/name is not transmitted

Calling is displayed.

Speaker mode

In speaker mode, instead of holding the handset to your ear you can put it down, for example on the table in front of you. This allows other people to participate in the call.

Activating/deactivating speaker mode

Activating while dialling



Enter the number and press the speaker key.

- ▶ You should inform your caller before you use the speaker function so that they know someone else is listening.

Switching between earpiece and speaker mode



Press the speaker key.

During a call or when listening to the answering machine (Gigaset C330 A only), activate or deactivate speaker mode.

If you wish to place the handset in the base/charging cradle during a call:

- ▶ Press and hold the speaker key  while placing the handset in the base.

Adjusting the earpiece/speaker volume during a call

To adjust the earpiece or speaker volume during a call:



Use the control key to adjust the volume (five levels).

Switching to mute

You can deactivate the microphone in your handset during an external call.



Press the mute key to mute the handset.



Or:



Press the display key. The display shows **Mute On**.

Press the key again to reactivate the microphone.

Please note

If the telephone is muted, no keys except the mute key  and the end call key  will work.

Battery status control during a call

The battery charging state is shown on the display symbol bar (→ page 5).

If during a call the battery status falls below a level that could impair the quality of the connection, the handset will beep at a 60-second interval and **Low Battery** is displayed. If possible, the caller ID and the repertory dialling memory are saved before the handset loses power. If the handset loses power the call is transferred to the base in speaker mode.

IP dialling

You can use IP dialling to economically make international calls.

Requirement: You own an IP dial service card of your provider and the IP code is stored in the phone.

In idle mode:



Enter the IDD number.



Press and hold the IP key.



Press the talk key.

Or:



Press the display key.

Your telephone will automatically pick the line and add the IP code stored in the phone as a prefix to the IDD phone number.

In talk mode:



Press the talk key.



Press and hold the IP key.
The service provider is called.
You will hear an announcement of your service provider.



Enter the IDD number.

If no IP number is stored in the directory an error message is output.

You can also dial the IP number for numbers from the directory, call list, or redial list and dial the IP code directly.

The prefix function (→ page 43) is disabled when using IP dialling.

Storing IP numbers

To use IP dialling via the  key the IP code must be stored in the phone. The IP code consists of the IP dial number, card number and PIN. You can also assign a name. The size of IP code is 24 digits and 12 characters.

Viewing the IP number



Press and hold the IP key.

If an IP number is stored, it is displayed. If no number is stored you can now enter one.

Storing an IP number

To store an IP number:



Press and hold the IP key.



Enter the IP number.



The IP number must be entered in the following format:

IP code  language  IP card number

 PIN 

Example: 17901P1P31108888#P9888#

IP code: e.g. 17910 = China Unicom

Language:  or  or 
e.g. 1 = Mandarin

Pause: Press and hold the  key.

Editing an IP number



Press and hold the IP key.



Press the display key.



Select **Edit Entry** and press **OK**.



Change the name and press **OK**.



Change the number and press **Save**.

Use the  display key to erase a character to the left of the cursor.

Deleting an IP number



Press and hold the IP key.



Press the display key.



Select **Delete Entry** and press **OK**.

Making internal calls

Making internal calls



Internal calls between the base and the handset or to other handsets registered on the same base are free.

An internal call is indicated on the display via the following symbol:





The name of the calling station (base or handset) is also shown.

Calling the base or a specific handset

-  Initiate internal call.
-  Select a handset or **Base**.
-  Press the talk key or the **Select** display key.

Calling all

-  Initiate internal call.
- Call All** Select menu option and
-  Press the talk key.

All handsets and the base are called.

Ending a call

-  Press the end call key.



Please note

When selecting **Call All** the connection will be established to the first answering participant. All the others cannot participate.

Transferring a call

You can transfer an external call to the base or another handset (connect).

During an external call:

-  Open the list of handsets.
-  Select the base, a handset or **Call All** and press **OK**.

When the internal participant answers:

- ▶ If necessary, announce the external call.

-  Press the end call key or the **End** display key.



The external call is transferred to the base or the other handset.

If the internal participant does **not** answer or the line is busy, press the display key **Back** to return to the external call.

Internal consultation/ conference calls

When you are conducting an **external** call, you can call an **internal** participant at the same time for consultation or hold a conference call between all 3 participants.

You are conducting an **external** call:

-  Open the list of handsets.
-  Select the base or a handset and press **OK**.
You are connected to the internal participant.

Either:

- End** Press the display key.
You are reconnected with the external participant.

Or:

- Conf.** Press the display key.
All 3 participants are connected with each other.

Ending a conference call

-  Press the end call key.

If an **internal** participant ends the call, the other remains connected to the external participant.

Please note

Conferences are only possible between one external and two internal participants.

Accepting/rejecting call waiting

If you receive an **external** call during an **internal** call, you will hear the call waiting tone (short tone). The caller's number or name will appear in the display if Calling Line Identification is enabled.

Ending an internal call, accepting an external call

Accept Press the display key.

The internal call is **ended**. You are connected to the external caller.

Barging in to an external call

Requirement: The **Conference** function must be activated.

You are conducting an external call. An internal participant can listen in on this call and take part in the conversation. All participants are made aware of the "barging in" by a signal tone.

Enabling/disabling barge in

Menu → **System Setting** → **Add. Features** → **Conference**

 Select **On** or **Off** and press **OK**.

Internal barge in

The line is engaged with an external call. Your screen will display information to that effect. You want to listen in to the external call.

 Press the talk key.

You can listen in to the call. All participants hear a signal tone. During this time, this handset displays the **Conference** message and it is not possible to dial another number from this handset.

Ending barge in

 Press the end key.

All participants hear a signal tone.

If the **first** internal participant ends the call, the one who has "barged in" remains connected to the external participant.

Using the directory and lists

Using the directory and lists

The following options are available for storing information on calls, contacts and numbers:

- ◆ Directory
- ◆ Redial list, → page 37
- ◆ Call list, → page 38

Please note

The directory, call lists and shortcuts are saved in the base and shared with all registered handsets.

Directory

You can save up to 150 entries in the directory, which are stored in the base and shared by all registered handsets → page 20).

If the handset cannot connect to the base, the display shows **Out of range**.

In each directory entry, you can save one number, an associated name and a shortcut for this entry → page 37.

Editing the directory and storing or deleting an entry are only possible via handset.

For how to write and edit text, → page 52.

Opening the directory

To open the directory in idle status

 Press the control key.

Storing a number in the directory

Menu Press the display key.

 Select **New Entry** and press **OK**.

 Enter the name (max. 12 characters) and press **OK**.

 Enter the number (max. 24 digits).

Save Press the display key to save the entry.

- ▶ To insert a pause, e.g. if an prefix is added automatically, press and hold the  key.

Or:

 Enter the number (max. 24 digits) and press **Save**.

 Enter the name (max. 12 characters) and press **OK**.

Save Press the display key to save the entry.

Order of directory entries

Directory entries are generally sorted alphabetically by name. Spaces and digits have priority.

The sort order is as follows:

1. Digits (0–9)
2. Space
3. Other characters
4. Letters (alphabetical)

To get round the alphabetical order of the entries, insert a space or a digit in front of the first letter of the name. These entries will then move to the beginning of the directory.

Selecting a directory entry



 Open the directory.

- ▶ Use  to scroll through the entries until the required name is selected.

Or:

- ▶ Enter the first letters of the name; if necessary scroll to the entry with the  key.

Dialling with the directory

 →  Open the directory, select the desired entry.



 Press the talk key.
The number is dialled.

Viewing entries



 Select the entry.

View Press the display key. The entry is displayed.

Editing entries





-  Select the entry.
- Menu** Press the display key.
-  Select **Edit Entry** and press **OK**.
- <C** Use the display key to delete the current entry.
-  Change the entry as desired and press **Save** to save the changes.

Deleting an entry

-  Select the entry.
- Menu** Press the display key.
-  Select **Delete Entry** and press **OK**.



Assigning a shortcut

You can assign shortcut numbers for up to 8 entries.

-  →  Open the directory, select an entry.
- Menu** Press the display key.
-  Select **Shortcut** and press **OK**.
-  Select the shortcut number (Shortcut 2, Shortcut 3...) and press **OK**.

Note that Shortcut 0 is reserved for the IP number. When **0** is pressed and held in redial, the IP number is inserted in front of the redial number.

Deleting all entries from the directory

-  →  Open the directory, select any entry.
- Menu** Press the display key.
-  Select **Delete List** and press **OK**.
- OK** Press the display key to confirm deletion of all entries.

Copying the displayed number to the directory

You can copy numbers displayed in a list, e.g. the call list or the redial list, to the directory.

A number is displayed:

Menu → **Copy to Directory**



▶ Complete the entry, → page 36.

Redial list

The redial list contains the 30 numbers last dialled with the handset (max. 24 digits). If one of the numbers is in the directory, the corresponding name will be displayed.

The redial list is arranged in reverse chronological order, i.e. the last dialled number is the first number in the list.

Manual redial

- Press the display key.
-  Select the entry to be dialled.
-  Press the talk key. The number is dialled.

When a name is displayed, you can display the corresponding phone number by pressing the display key **View**, Managing entries in the redial list

- | Press the display key.
-  Select an entry.
- Menu** Open menu.

The following functions can be selected with :

Copy to Directory

Copy an entry to the directory (→ page 37).

Delete Entry

Delete the entry after a confirmation.

Delete List

Delete all entries after a confirmation.

Using the directory and lists

Call lists

Requirement: Calling Line Identification,
→ page 32

The telephone stores a maximum of 50 numbers in the call list. Calls of the following types are available:

- ◆ Accepted calls
- ◆ Missed calls

You can decide which call type should be listed: all calls or only missed calls (→ page 38).



The message  key flashes as soon as a **new** call arrives in a the list.

In **idle status**, the display shows a symbol for the new missed call.

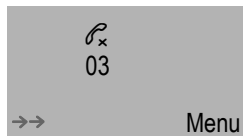
The number of **new** entries is displayed under the corresponding symbol.



Opening the call list

-  Press the message key.
-  Select **All Calls** or **Missed Calls** (depending on your **Call List Type** setting) and press **OK**.

List entry

The calls are displayed in chronological order.

Example of list entries:

New call	2/2
0678912345678	
02.08	16:05
Back	Menu

- ◆ List type (in header)
- ◆ Number of this call / total number of calls in the list

- ◆ Number or name of caller (if number and name are both transmitted, they are displayed alternately).
- ◆ Date and time of call

Dialling from the call list

To return the selected call:

 Press the talk key.

Managing the call list

Press the **Menu** display key to select the following options:

Copy to Directory

Copying a displayed number to the directory (→ page 37).

Delete Entry

Delete selected entry.

Delete All

Delete all entries.

When you quit the call lists, all entries are set to the status "old"; i.e. the  symbol is no longer displayed.

Setting the call list type

The call list displays:

- ◆ **All Calls** or only
- ◆ **Missed Calls**.

You can define which kind of calls should be displayed.

Menu → **System Setting** → **Call List Type**

 Select **Call List Type** and press **OK**.

 Select **All Calls** or **Missed Calls** and press **OK**.

Handset settings

Your handset is preconfigured, but you can change the settings to suit your individual requirements.

Changing the display language



You can view the display texts in Chinese and English.

Menu → HS Setting → Language

 Select the language and press **OK**.

If you accidentally choose a language you do not understand:

▶ Press the **right display key** to open the menu.









  Press key in sequence and then press the **right display key** twice.

 Select the correct language and press the **right display key**.









Setting the date and time

Menu → Date/Time → Date/Time

 Enter the year, month and day as an 8-digit number via the keypad. The first two digits (20) are fixed, i.e. you only have to enter six digits.

E.g.         for 26/09/2013.

OK Press the display key.

 Enter the hours and minutes in 4-digit format via the keypad, e.g.,         for 07:15 am.

OK Press the display key to save your settings.

Setting the alarm clock

Requirement: The date and time have already been set (→ page 39).

In idle status, the  symbol and wake-up time are displayed.

A wake-up call is signalled on the display and with the selected ringtone (→ page 2). The wake-up call sounds for 60 seconds.

During a call, the wake-up call is only signalled by a short tone.

Activating/deactivating the alarm clock

Menu → Date/Time → Alarm Clock → Activation

 Activate or deactivate the alarm and press **OK**.

Off: The alarm is deactivated

Once: The alarm is executed once at the specified time.

Daily: The alarm is executed daily at the specified time.

Setting the alarm time

Menu → Date/Time → Alarm Clock → Alarm Time

 Enter the hours and minutes in 4-digit format via the keypad and press **OK**.

Handset settings

Audio settings

The **Audio Setting** menu can be opened in two different ways:

 Using the control key.

Or via the main menu:

Menu → **Audio Setting**

In the following the menu path is used.

Changing the speaker/earpiece volume

You can set the loudspeaker volume for handsfree talking and the earpiece volume to five different levels.

In idle status:

Menu → **Audio Setting** → **Call Volume**

 Set the earpiece volume.

 Scroll to the **Handsfree Volume:** line.

 Set the speaker volume.

Save Press the display key if necessary to save the setting permanently.

Setting the volume during a call:

 Press the control key.

 Select volume.

The setting will automatically be saved after approximately 3 seconds, if not then press the display key **Save**.

Changing ringtones

You can change the volume and the ringtone.

Setting the volume

You can choose between five volumes.

In idle status:

Menu → **Audio Setting** → **Ringer Setting** → **Ringer Volume**

 Set the volume for incoming calls.

Save Press the display key to save the setting.

Setting the ringtone

You can select a ringtone from a list of 10 pre-loaded ringtones.

In idle status:

Menu → **Audio Setting** → **Ringer Setting** → **Ringer Melody**

 Select a melody for incoming calls.

Save Press the display key to save the setting.

Activating/deactivating the ringtone

You can deactivate the ringtone on your handset before you answer a call or when the handset is in idle status; the ringtone can be deactivated permanently or just for the current call. The ringtone cannot be reactivated while an external call is in progress.

Deactivating the ringtone permanently

 Press and **hold** the star key.

The  symbol appears in the display.

Reactivating the ringtone

 Press and **hold** the star key.

Deactivating the ringtone for the current call

Silence Press the display key.

For deactivating the ringtone with time control, → page 41.

Activating/deactivating advisory tones

Your handset uses advisory tones to tell you about different activities and statuses. The following advisory tones can be activated/deactivated independently of each other:

- ◆ **Key tone:** every key press is confirmed
- ◆ **Confirmation tone** (ascending tone sequence): at the end of an entry/setting and when a new entry arrives in the answering machine list or call list
- ◆ **Battery low beep:** the battery requires charging.

In idle status:

Menu → **Audio Setting** → **Key Tones**



Select **On** to activate or **Off** to deactivate the **Key Tones**. Confirmation tone und error tone is not affected.

OK Press the display key to save the settings.

Setting the display

Setting the screensaver

You can set a picture or the time to be displayed as a screensaver when the handset is in idle status. This will replace the idle status display. It may conceal the date, time and name. The screensaver is not displayed in certain situations, e.g. during a call or if the handset is de-registered.

Menu → **HS Setting** → **Screen Saver**



Select **On** to activate or **Off** to deactivate the screen saver.

OK Press the display key to save your setting.

When the screensaver conceals the display, **briefly** press any key to show the idle display.

Setting the contrast

You can set the level of the display brightness.

Menu → **HS Setting** → **Contrast**



Select the desired level (3 levels) and press **OK**.

Activating/deactivating auto answer

If you activate this function, when you receive a call you can simply lift the handset out of the charging cradle without having to press the talk key .

Menu → **HS Setting** → **Auto Answer**



Select **On** to activate or **Off** to deactivate the auto answer function for the handset and press **OK**.

System settings

System settings apply to the entire phone system. They can be set on the base or on any registered handset.

Deactivating the ringtone with time control

You can deactivate the ringtone for the base and all registered handsets with time control. The ringtone is deactivated between the defined start and end time.

Menu → **System Setting** → **Time Control**



Select **On/Off** and press **OK**.



Select **On** and press **OK**.



Select **Start&end** and press **OK**.



Enter the time for starting time control (**Silent from 00:00**) and press **OK**.



Enter the time for ending time control (**to 00:00**) and press **OK**.

Handset settings

System reset

Menu → System Setting → System Reset

OK Press the display key to confirm system reset.

Please note

The system settings are reset to default values for the base and all registered handsets. The directory entries are not changed.

Protecting against unauthorised access

Protect the system settings of the base with a PIN known only to yourself. The system PIN must be entered when, for example, registering/de-registering a handset to/from the base or when restoring the default settings.

You can change the 4-digit system PIN set on the base (default setting: **0000**) to a 4-digit PIN known only by you.

Menu → System Setting → System PIN



Enter the current system PIN and press **OK**.



Enter your new system PIN and press **OK**.

Connecting the telephone to the PABX

The following settings are only necessary if your PABX requires them; see the PABX user guide. The settings can only be made via a registered handset (→ page 29).

Changing the dialling mode

The following dialling modes can be selected:

- ◆ Tone dialling (DTMF)
- ◆ Pulse dialling (DP)

Menu → **System Setting** → **Add. Features** → **Dialing Mode**

 Select the dialling mode and press **OK**.

Setting recall



Recall specifies the flash time (break) used for tone dialling when a recall (e.g. a consultation call) is activated. Your phone is preset at the factory for operation on the main connection. For operation on a PABX, you may have to change this value. Please refer to the user guide for your PABX.

Menu → **System Setting** → **Add. Features** → **Flash Time**

 Select the recall time and press **OK**.
Possible values are:
80 ms, 100 ms, 120 ms, 180 ms,
250 ms, 300 ms, 600 ms, 800 ms.

Setting an automatic prefix

You can set a prefix which is automatically added to a phone number with at least 5 digits. This prefix can be used to dial into the outside line when operating the device on a PABX. A pause is added automatically after the prefix.

The number must be dialled in idle mode, i.e. first  then .

Activating/deactivating the automatic prefix

Menu → **System Setting** → **Auto Prefix** → **Activation**

 Select **On** or **Off** and press **OK**.

Setting the prefix number

Menu → **System Setting** → **Auto Prefix** → **Prefix No.**

 Enter the prefix number and press **OK**.

Example: Auto Prefix = On and set to 65

You dial	Actually dialled number
1234	1234
12345	65P12345
#12345	65P#12345

Temporarily switching to tone dialling (DTMF)

If your PABX still operates with dial pulsing (DP), but you need tone dialling for a connection (e.g. to listen to a network mail box) you must switch to tone dialling for the call.

Requirement: You are conducting a call or have already dialled an external number.

During the call:

 Press the star key.

After the call is ended, dial pulsing is automatically activated again.

Operation via the base

Operating the answering machine (Gigaset C330 A only)

The answering machine can be used to record incoming messages or memos.

The answering machine is operated via the keys on the base, the handset or by remote operation (from another telephone/mobile phone). You can record your own announcement message. You can also record memos (only on the base).

Please note







If the answering machine is being operated from a handset or if it is recording a message, it cannot be operated from the base.

The maximum recording time is 30 minutes. A maximum of 59 messages can be recorded.

The date and time of each message is logged and displayed during the playback. If Calling Line Identification is activated, the caller's number is displayed.

Operation via the base



The following keys on the base are used to operate the answering machine:

	On/Off key and LED
	Skip back key
	Play/stop key
	Skip forward key
	Delete key
	Record key

Activating/deactivating the answering machine

- ▶ Press the  key to activate/deactivate the answering machine.



When the answering machine is activated:

- ◆ The LED on the  key lights up.
- ◆ The  symbol is displayed in the symbol line.

Setting the answering machine mode

You can use the answering machine in two different modes.

- ◆ In **Answer & Record** mode, the caller hears the announcement and can then leave a message.
- ◆ In **Announce. Only** mode, the caller hears your announcement but cannot leave a message.

	Press and hold the On/Off key.
	Press 1 to select Answer & Record (AC) mode or
	2 to select Announce. Only (AO) mode.

Playing back messages

Message indication

If new messages/memos are available:



- ◆ The  key flashes.
- ◆ The number of new messages/memos is displayed.

If the memory is full you will hear an end tone, the  flashes fast, the recording is aborted, and the call recorded up to that point is listed in the answering machine list as a new message.

Playing back new messages

 Press the key to play back all messages and memos.

If there are new messages, playback begins with the first new message. After the last new message you will hear the end tone and an announcement.

To adjust the volume during message playback:  = quieter;  = louder.



Playing back old messages

You can listen to old messages if there are no more new messages. Begin playback as described under "Playing back new messages".

After the entry time and date have been played back (after approx. 3 seconds) a new message assumes the status "old".

Stopping and controlling playback

During message playback:

-  Stop playback.
-  Go to the start of the current message. **Press twice** to go back to the previous message.
-  Skip to next message. **Press twice** to skip to the next but one message.

Deleting messages



During playback or pause:

 Press the key to delete the message.

You can only delete all old messages if there are no new messages.

Picking up a call from the answering machine

You can pick up a call while the answering machine is recording or is being operated via remote operation:

 Lift the receiver or press the speaker key .

Recording stops and you can speak to the caller.

If 2 seconds of the call have already been recorded when you pick it up, the call will be displayed as a new message.

Activating/deactivating call screening

While a message is recording, you can screen calls via the loudspeaker of the base and registered handsets.

You can activate or deactivate call screening permanently via the handset, → page 47.

Recording an announcement

The phone is supplied with a pre-recorded announcement. If a personal announcement has not been recorded, the relevant pre-recorded announcement is used.

 Press and hold the key.

 Press 1 to select **Answer & Record (AC)** mode or

 Press 2 to select **Announce. Only (AO)** mode.

▶ Now speak your announcement (at least 3 seconds).

 Press the key to end the recording.

Cancel recording with .

After recording, the announcement is played back for you to check.

▶ Press  to end the playback.

▶ Press  to delete the recording.

Please note:

- ◆ Recording ends automatically if the maximum recording time of 180 seconds is exceeded.
- ◆ If you cancel the recording, the pre-recorded announcement will be used again.

Operation via the handset

Operation via the handset

The handset loudspeaker activates **automatically** if you receive an acoustic prompt or message while operating the answering machine. You can switch it off with the speaker key .

Activating/deactivating the answering machine

Menu → **Voice Mail** → **Answerphone**

 Select **On** and press **OK**. Select **Off** to deactivate the answering machine.

When the answerer machine is activated, the  symbol is displayed at the top of the screen.

The LED lights up on the base ( page 44).

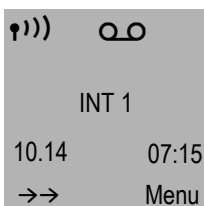

Playing back messages

Message indication

The message  key flashes as soon as a **new message** arrives in a the list.

In **idle status**, the display shows a symbol for the new message.

The number of **new messages/ memos** is displayed under the corresponding symbol.



Playing back new messages

To play back all messages and memos:

 Press and **hold** this key.

Or:

 Press the message key and press **OK**.

Or:

Menu → **Voice Mail** → **Play Messages**

If there are new messages, playback begins with the first new message. After the last new message you will hear the end tone and an announcement.

Adjust volume during message playback:

Options Press the display key.

 Select **Volume** and press **OK**.

 Select the desired volume and press **OK**.

Playing back old messages

You can listen to old messages if there are no more new messages. Begin playback as described under "Playing back new messages".

 Use the control key to select the message you want to be played back.

After the entry time and date have been played back (after approx. 3 seconds) a new message assumes the status "old".

Stopping and controlling playback

During message playback:

 Press the end key to stop playback.

Deleting messages

Deleting the current message

During playback:

Delete Press the display key.

Deleting all old messages

During playback:

Options Press the display key.

 Select **Delete All Old** and press **OK**.

OK Confirm the action by pressing the display key.

Picking up a call from the answering machine

You can pick up a call while the answering machine is recording or is being operated via remote operation:

 Press the talk key.

Recording stops and you can speak to the caller.

If 2 seconds of the call have already been recorded when you pick it up, the call will be displayed as a new message.

Activating/deactivating call screening

While a message is recording, you can screen calls via the loudspeaker of the base and registered handsets.

Permanently activating/deactivating call screening

Menu → **Voice Mail** → **Call Screening**

 Select **On** to activate or **Off** to deactivate call screening and press **OK**.

Call screening can be simultaneously activated on the base and handset.

Deactivating call screening for the current recording

You can deactivate the function on the telephone during the recording.

Silence Press the display key.

Announcements

Recording an announcement

The phone is supplied with a pre-recorded announcement. If a personal announcement has not been recorded, the relevant pre-recorded announcement is used.

Menu → **Voice Mail** → **Announcement**

▶ Select **Answer & Record** or **Announce Only** and press **OK**.

▶ Select **Rec. Announcement** and press **OK** to start recording.

▶ Now speak your announcement (at least 3 seconds).

OK Press the display key to end the recording.

Cancel recording with **Back** or .

After recording, the announcement is played back for you to check.

▶ Press **Back** to end the playback.

Please note:

- ◆ Recording ends automatically if the maximum recording time of 120 seconds is exceeded.
- ◆ If you cancel the recording, the pre-recorded announcement will be used again.

Remote operation

Playing back the announcement

Menu → **Voice Mail** → **Announcement**

- ▶ Select **Answer & Record** or **Announce Only** and press **OK**.
- ▶ Select **Play Announcement** and press **OK**.

If you have not recorded a personal announcement, the relevant pre-recorded announcement is played.

- ▶ Press **Back** to end the playback.

Deleting the announcement

Menu → **Voice Mail** → **Announcement**

- ▶ Select **Answer & Record** or **Announce Only** and press **OK**.
- ▶ Select **Del. Announcement** and press **OK**.
- ▶ Press **OK** to confirm your setting.

Once you have deleted your announcement, the relevant pre-recorded announcement will be used again.

Setting the answering machine mode

You can choose between **Answer & Record** and **Announce Only**.

Menu → **Voice Mail** → **Answer Mode**

- ▶ Select the answering machine mode and press **OK**.

Answer & Record

The caller hears the announcement and can then leave a message.

Announce Only

The caller hears the announcement but cannot leave a message.

Setting the ring delay

The answering machine has already been preset at the factory. Individual settings can be adjusted using the handset.

You can set the number of rings the telephone will wait before the answering machine answers a call.

Menu → **Voice Mail** → **Ring Delay**



Use the control key to select the number of rings and press **OK**. Possible values:
1 rings, ((müßte "1 ring" heißen)) **3 rings**, **6 rings**, **9 rings** or **Auto**.

Remote operation

You can check and activate your answering machine from any other telephone (hotel, pay phone etc.).

Requirements:

- ◆ You have set a system PIN other than 0000 (→ page 42).
- ◆ The phone you are using for remote operation has tone dialling (DTMF), i.e. you hear different tones when you press the keys. Alternatively, you can use a code transmitter (available from a retailer).

Calling the answering machine



Dial the number. The announcement will be played.

When the announcement is finished, you can record a message or begin remote access.

- ▶ Press any key to skip the announcement.

If the answering machine memory is full, the message "Memory Full" will be announced after the 10th ring.

Operating the answering machine remotely



When you hear the announcement playing, press # and then enter the system PIN.

You can now operate the answering machine with the keypad. You will be informed about the keys to be used for operation.

▶ Press **7 PERS** to replay the information.

If you press the talk key  on the handset during a remote operation on the answering machine, the operation will be terminated.

Replaying messages remotely

You will be informed whether any new messages have been recorded. The function list is replayed. Press 2 to play back the messages.

The following operations are possible by pressing the corresponding key:

- 1** END Return to the start of the current message. Press twice to go back to the previous message.
- 3** DEF Go to the next message.
- 2** AK- Stop playback. Press again to replay the messages, starting with the first new message. If there are no new messages, the replay starts with the first old message.
- 0** SP Delete the current message.
- 7** PERS Replay the function list.
- 6** MNO Switch off the answering machine.

Activating/deactivating the answering machine remotely

Activating remotely

In case the answerer machine is deactivated it will announce "answering machine off" after the 10th ringing.



Enter the system PIN within seven seconds.



Activate the answering machine.

Deactivating remotely

You can deactivate the answering machine remotely, if it is not in play mode.



Deactivate the answering machine.

Customer Service & Assistance

Customer Service & Assistance

If you have any question, reach us by

Web site: www.gigaset.com/cn

Hotline: 4006 706 007

Questions and answers

If you have any questions about the use of your phone, you can contact us 24/7 at www.gigaset.com/service.

The table below contains a list of common problems and possible solutions.

<p>The handset display is blank.</p> <ol style="list-style-type: none"> The handset is not switched on. <ul style="list-style-type: none"> Press and hold the end call key . The battery is flat. <ul style="list-style-type: none"> Charge the battery or replace it (→ page 13).
<p>Out of range is shown on the display.</p> <ol style="list-style-type: none"> The handset is outside the range of the base. <ul style="list-style-type: none"> Move the handset closer to the base. The base is not switched on. <ul style="list-style-type: none"> Check the mains adapter of the base (→ page 11).
<p>Register HS is shown on the display.</p> <p>Handset has not been registered with the base or has been de-registered.</p> <ul style="list-style-type: none"> Register the handset (→ page 29).
<p>Handset does not ring.</p> <p>The ringtone is deactivated.</p> <ul style="list-style-type: none"> Activate the ringtone (→ page 40).
<p>You cannot hear a ringtone/dialling tone from the fixed line network.</p> <p>The phone cord supplied has not been used or has been replaced by a new cord with the wrong pin connections.</p> <ul style="list-style-type: none"> Please always use the phone cord supplied or ensure that the pin connections are correct when purchasing from a retailer (→ page 11).
<p>Error tone sounds after system PIN prompt.</p> <p>You have entered the wrong system PIN.</p> <ul style="list-style-type: none"> Enter the correct system PIN.

Forgotten the system PIN.

- ▶ Contact the service hotline (→ page 50).

The other party cannot hear you.

You have pressed the mute key . The handset is "muted".

- ▶ Activate the microphone again (→ page 18).

The number of the caller is not displayed.

Calling Line Identification is not enabled.

- ▶ **The caller** should ask the network provider to enable Calling Line Identification (CLI).

You hear an error tone when keying an input (a descending tone sequence).

Action has failed/invalid input.

- ▶ Repeat the operation.
Watch the display and refer to the user guide if necessary.

You cannot listen to messages on the network mailbox.

Your PABX is set for dial pulsing.

- ▶ Set your PABX to tone dialling.

Gigaset C330 A only:

No time is specified for a message in the call list.

Date and time have not been set.

- ▶ Set the date/time (→ page 14).

The answering machine announces "PIN is incorrect" during remote operation.

- You have entered the wrong system PIN.
 - Enter the system PIN again.
- The system PIN is still set to 0000.
 - Change the system PIN (→ page 42).

The answering machine is not recording any messages/has switched to announce only.

Its memory is full.

- ▶ Delete old messages.
- ▶ Play back new messages and delete.

Exclusion of liability

Some displays may contain pixels (picture elements), which remain activated or deactivated. As a pixel is made up of three sub-pixels (red, green, blue), it is possible that pixel colours may vary.

This is completely normal and does not indicate an error.

Appendix

Care

- ▶ Wipe the base station, charging cradle and handset with a **damp** cloth (do not use solvent or a microfiber cloth) or an antistatic cloth.
- ▶ Impairments in the high-gloss finish can be carefully removed using display polishes for mobile phones.

Never use a dry cloth. This can cause static.

Contact with liquid

If the base/handset comes into contact with liquid:

1. **Unplug the power supply (base).**
2. **Switch off the handset and remove the battery pack immediately.**
3. Allow the liquid to drain from the device.
4. Pat all parts dry.

Place the base (the keypad facing down) and the handset with the battery compartment open and the keypad facing down in a dry, warm place **for at least 72 hours (not in a microwave, oven etc.)**.

5. **Do not switch on the device again until it is completely dry.**

When it has fully dried out, you will normally be able to use it again.

In rare cases, contact with chemical substances can cause changes to the telephone's exterior. Due to the wide variety of chemical products available on the market, it was not possible to test all substances.

Specifications

Technology:

Nickel-metal-hydride (NiMH)

Size: AAA (Micro, HR03)

Voltage: 1.2 V

Capacity: 650 mAh

We recommend the following battery types, because these are the only ones that guarantee the specified operating times, full functionality and long service life:

- ◆ SHP 650mAh
- ◆ Corun 650mAh

The device is supplied with two approved batteries.

Handset operating times/charging times

The operating time of your Gigaset handset depends on the age of the batteries and the way they are used. (All times are maximum possible times).

Standby time (hours)*	180
Talktime (hours)	8
Charging time in charging cradle (hours)	16

Due to the constant progression in battery development, the list of recommended batteries in the FAQ section of the Gigaset Customer Care pages is regularly updated:

www.gigaset.com/service

Base power consumption

In standby mode (backlight off):

Gigaset C330: approx. 0.9 watt

Gigaset C330 A: approx. 1.0 watt

During the call (speaker mode):

Gigaset C330: approx. 3.0 watt

Gigaset C330 A: approx. 3.0 watt

Appendix

General specifications

WDCT standard	is supported
Radio frequency range	2402.784~2480.544 MHz
No. of channels	91
Bit rate	1.152 Mbit/s
Modulation	GFSK
Peak output power	25 mW, EIRP
Range	up to 300 m outdoors, up to 50 m indoors
Base power supply	100-240V ~50/60Hz
Environmental conditions in operation	+5°C to +45°C, 20% to 75% relative humidity
Dialling mode	DTMF (tone dialling)/ DP (dial pulsing)

Pin connections on the telephone jack

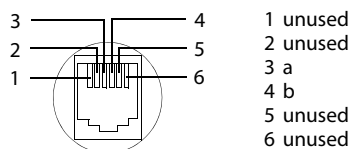

Writing and editing text

The following rules apply when writing text:

- ◆ Each key between **0** and **9** is assigned several letters and characters.
- ◆ Control the cursor with **←** **→** **↑** **↓**. Press and **hold** **←** or **→** to move the cursor **word by word**.
- ◆ Characters are inserted at the cursor position.
- ◆ Press the star key *** Δ** to display the table of special characters. Select the required character using **←** or **→** to insert the character at the cursor position.

- ◆ Press **<C** display key to delete the **characters** to the left of the cursor. Press and **hold** to delete the **word** to the left of the cursor.
- ◆ The first letter of the name of directory entries is automatically capitalised, followed by lower case letters.

Writing names

Press the relevant key several times to enter letters/characters.

Standard characters

	1x	2x	3x	4x	5x	6x	7x	8x	9x	10x	11x	12x	13x	14x	15x	16x	17x	18x	19x	20x	21x				
1 sp	1	@	_	#	=	<	>	()	&	€	£	\$	¥	[]	{	}	α						
2 abc	a	b	c	2																					
3 def	d	e	f	3																					
4 ghi	g	h	i	4																					
5 jkl	j	k	l	5																					
6 mno	m	n	o	6																					
7 pqrs	p	q	r	s	7																				
8 tuv	t	u	v	8																					
9 wxyz	w	x	y	z	9																				
0 sp	□	.	0	,	/	:	;	"	'	!	¡	?	¿	*	+	-	%	\	^	~					

*) Space

Setting upper/lower case or digits

Press the hash key **[# ↔]** **briefly** to switch from "Abc" mode to "abc" and from "abc" to "Abc" (upper case: 1st letter upper case, all others lower case). Press the hash key **[# ↔]** **before** entering the letter.

You can see in the display whether upper case, lower case or digits is selected.

Index

Index

A

- Accepted calls 21, 38
- Advisory tones
 - activating/deactivating (handset) 41
- Alarm clock
 - activating/deactivating 39
 - setting time 39
- Alarm clock (only on handset) 39
- Announcement
 - deleting (handset) 48
 - playing back (handset) 48
 - recording (base) 45
 - recording (handset) 47
- Answering machine 44
 - activating/deactivating (base) 44
 - activating/deactivating (handset) 46
 - activating/deactivating remotely 49
 - announcement (base) 45
 - announcement (handset) 47
 - control keys (base) 44
 - display symbol (base) 44
 - display symbol (handset) 46
 - LED 44
 - memory full indication 44
 - message length 48
 - mode 44
 - new messages (base) 44
 - picking up call (base) 45
 - picking up call (handset) 47
 - recording time 44
 - remote operation 48
 - ring delay 48
- Answering machine mode
 - Announcement Only 44
 - Answer & Record 44
 - setting 48
- Automatic answer mode (handset) 41

B

- Barge in
 - enabling/disabling (handset) 35
 - ending (handset) 35
 - listening in to an external
 - call (handset) 35

Base

- answering machine control keys 44
- connecting 11
- display symbols 2
- setting up 11
- settings 23
- base settings
 - date and time 23
- Battery
 - charge state 5
 - charging control during a call 33
 - charging times 51
 - initial charging 14
 - inserting 13
- Battery cover, opening/closing 13
- Battery low beep
 - activating/deactivating 41

C**Call**

- accepting (base) 17
- accepting (handset) 31
- dialling (base) 17
- dialling (handset) 31
- ending (base) 17
- ending (handset) 31
- picking up from answering machine
 - (base) 45
 - (handset) 47

Call list

- copying entry to directory (base) 21
- copying entry to directory (handset) .. 38
- deleting (base) 21
- deleting (handset) 38
- deleting entry (base) 21
- deleting entry (handset) 38
- entry (base) 21
- entry (handset) 38
- opening (base) 21
- opening (handset) 38
- Call list (base) 21
- Call list (handset) 38
- Call list type
 - setting (handset) 38

Call screening	
activating/deactivating permanently (base)	45
activating/deactivating permanently (handset)	47
activating/deactivating temporarily (handset)	47
Call transfer (base)	18
Call transfer (handset)	34
Call waiting (base)	19
Call waiting (handset)	35
Calling Line Identification	17, 32
Care	51
Characters	
lower/upper case	53
standard	53
Charging cradle, connecting	12
CLI see Calling Line Identification	
Conference call	
ending (base)	19
ending (handset)	34
initiating (base)	19
initiating (handset)	34
Confirmation tone	
activating/deactivating (handset)	41
Connecting	
the base	11
the charging cradle	12
Consultation call (base)	19
Consultation call (handset)	34
Contact with liquid	51
Contrast, handset display	41
Control key	
handset	25
Customer service	50
D	
Date	
setting (base)	23
setting (handset)	39
date and time setting (base)	23
Dialling	
base	17
Dialling from call list (base)	21
Dialling from call list (handset)	38
Dialling mode	
changing (handset)	43

Directory	
copying number from list (handset) ..	37
deleting all entries (handset)	37
deleting entries (handset)	37
dialling number (handset)	36
editing entries (handset)	37
new entry (handset)	36
opening (base)	20
opening (handset)	36
Directory (base)	20
dialling number	20
order of entries	20
Directory (handset)	36
order of entries	36
Display	
changing language (handset)	39
Display (handset)	
setting the contrast	41
setting the screen picture	41
Display keys (handset)	25
Display symbols	
base	2
handset	4

E

Earpiece volume	
adjusting during a call (base)	18
adjusting during a call (handset)	32
setting permanently (base)	23
setting permanently (handset)	40
Entries	
correcting	26

F

FAQ	50
Flash time	
setting (handset)	43

G

Gigaset C330 A	
answering machine keys	2
Gigaset C330H overview	3

Index**H**

Handset	
activating/deactivating	26
battery charge state	5
control key	25
display keys	25
display symbols	4
idle display	5
main menu	26, 27
operating time	51
setting up	13
settings	39
signal strength to base	5
signalling	4
Handsfree mode	
base	17
handset	32
Hotline	50

I

Internal call (base)	18
Internal call (handset)	34
IP dialling (handset)	33
IP number	
deleting (handset)	33
storing (handset)	33

K

Key tone	
activating/deactivating (handset)	41
Keypad lock	
base	16
handset	26
symbol (base)	16
symbol (handset)	26

L

Language	
changing (handset)	39
LED	
answering machine (base)	1, 2
new message (handset)	3

M

Memo	44
recording	45
memorie	
one touch keys	22
Memory key	22

Menu

handset	26
main menu on handset	26
reverting in idle status	16, 27
submenus on handset	27

Menu tree

handset	27
---------	----

Message

deleting (base)	45
deleting (handset)	47
Message indication (handset)	46
Message key (MWI) (handset)	46

Message, new

indication (base)	44
indication (handset)	46
LED (handset)	3
playing back (base)	45
playing back (handset)	46

Message, old

deleting all (handset)	47
playing back (base)	45
playing back (handset)	46

Missed call

display symbol (base)	21
display symbol (handset)	38
Missed calls	21, 38

Mute

activating/deactivating (base)	18
activating/deactivating (handset)	32

N**Number**

copying to directory (handset)	37
dialling (base)	17
dialling (handset)	31
dialling from call list (base)	21
dialling from call list (handset)	38
dialling from directory (handset)	36
dialling vial memory key	22
storing in the directory (handset)	36

O

one touch memories	22
One-touch memory	22

P

- PABX 43
- Pack contents 10
- Pause
 - adding to a directory entry (handset) . 36
- Picture, handset display 41
- Pin connections 52
- Playback
 - starting (base) 45
 - starting (handset) 46
 - stopping/restarting (base) 45
 - stopping/restarting (handset) 46
- Power consumption 51
- Prefix
 - activating/deactivating (handset) 43
 - automatic 43
- Pulse dialling 43

Q

- Quick dialling (base) 17
- Quick dialling (handset) 31

R

- Recall flash time 43
- Redial (base) 20
- Redial (handset) 37
- Redial list
 - base 20
 - copying entry to directory (base) 21
 - copying entry to directory (handset) .. 37
 - deleting (base) 21
 - deleting entry (base) 21
 - deleting entry (handset) 37
 - handset 37
- Ringer
 - setting ringtone (base) 24
 - setting ringtone (handset) 40
 - setting volume (base) 23
 - setting volume (handset) 40
- Ringtone
 - activating/deactivating (base) 24
 - activating/deactivating (handset) 40
 - deactivating temporarily (base) 17
 - deactivating temporarily (handset) ... 31

S

- Safety precautions 9
- Security 9
- Service hotline 50
- Setting up
 - base 11
 - charging cradle 12
 - handset 13
- Signal strength 5
- Speaker (base)
 - activating/deactivating 17
- Speaker (handset)
 - activating/deactivating 32
- Speaker mode
 - activate/deactivate (base) 18
 - activate/deactivate (handset) 32
- Speaker volume
 - adjusting during a call (base) 18
 - adjusting during a call (handset) 32
 - setting permanently (base) 23
 - setting permanently (handset) 40
- Specifications 51
 - general 52
- Standard characters 53
- System PIN
 - changing (handset) 42

T

- Telephone jack, pin connections 52
- Temperature range 11
- Text, writing 52
- Time
 - setting (base) 23
 - setting (handset) 39
- Tone dialling
 - setting temporarily (handset) 43
- Tone dialling (DTMF) 43

W

- Writing text 52

Issued by
Gigaset Communications GmbH
Frankenstr. 2a, D-46395 Bocholt

© Gigaset Communications GmbH 2013
Subject to availability.
All rights reserved. Rights of modification reserved.
www.gigaset.com